

www.polymagnet.com

## 1002229

Align Polymagnets are engineered with a selective pattern that gives them a stronger holding force and unique alignment characteristics compared to conventional magnets. Standard magnets typically do not align with any level of precision when attaching to each other. These Align Polymagnets are designed provide a high holding force when aligned and very little attractive force when out of alignment. As these magnet approach alignment they provide a positive force toward the alignment position. This allows products and systems to be engineered with alignment behaviors that give them a unique user experience. These Polymagnets also have a high shear resistance along their long axis. Align Polymagnets exhibit a tightly controlled magnetic field that minimizes interference with sensitive devices. For more details visit [www.polymagnet.com/blog/align](http://www.polymagnet.com/blog/align).

### Features and Benefits

- Precise single position alignment

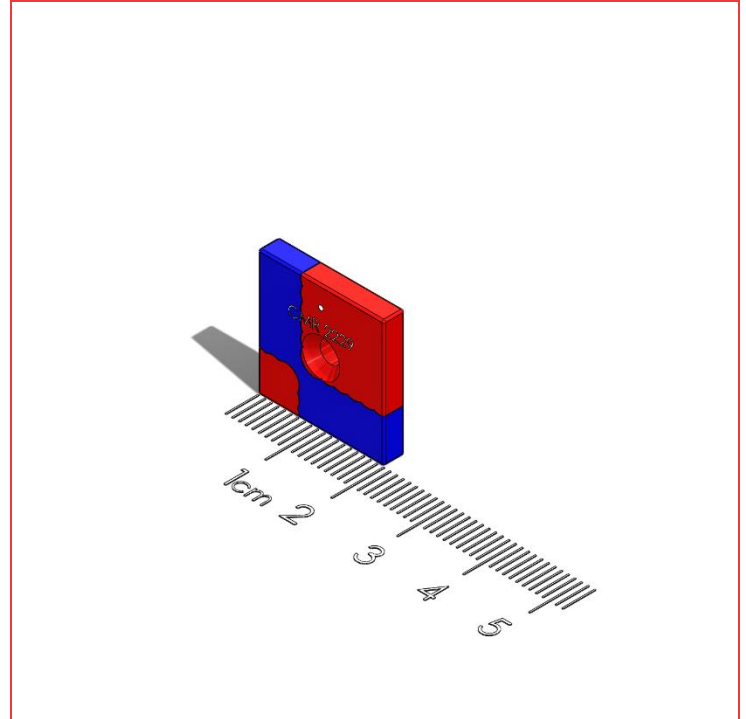

### Technical Specifications:

Dimensions:	0.75 x 0.75 x 0.125 in
	19.05 x 19.05 x 3.175 mm
Weight:	0.3oz (8.5g)
Material:	NdFeB
Magnet Grade:	N50
Coating:	NI-CU-NI
Temperature Rating:	140° F (60° C)
Holding Force at contact:	28lbs (124.6N)
Peak Shear Force at 0.060" (1.5mm) separation:	4.9lbs (21.6N)

### HOLDING FORCE VS SEPARATION DISTANCE MAGNET TO MAGNET

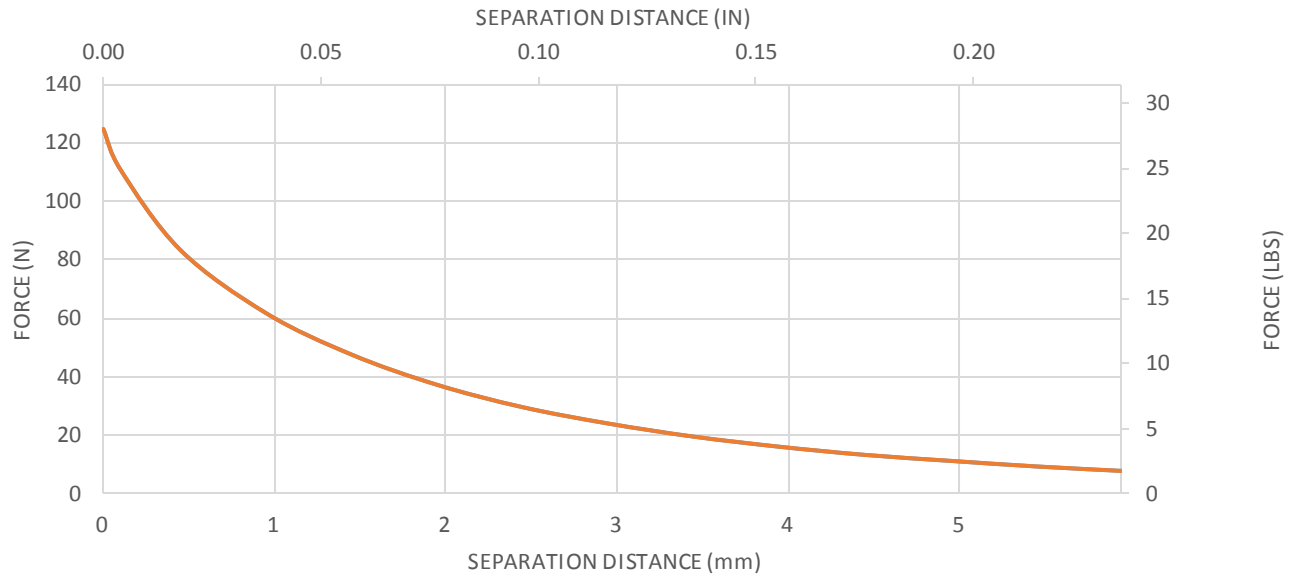

The holding strength for these Polymagnets can be enhanced in many applications by using a thin steel shunt directly against the back of the Polymagnet, and this shunt will also help limit stray fields from the magnet.

www.polymagnet.com

These Align Polymagnets provide superior linear alignment attributes compared to conventional magnets over their working range. A pair of 1002229/1002230 Polymagnets demonstrates a strong force toward their alignment position when offset on their long axis. These magnets can be used to align and attach components or accessories. By using multiple pairs in different arrangements the components can be made reversible or restricted to a particular orientation. Because of their alignment and shear resistance attributes these magnets can be used to transfer a linear force across a gap.

\*In the images below the polarity regions are indicated for the marked face of the magnet. North poles are indicated by the red regions, south poles are indicated by the blue regions.

Attract Force:	10.7lbs (47.4N)
Shear Force:	0lbs (0N)

Attract Force:	4lbs (17.8N)
Shear Force:	4.9lbs (21.6N)

0.2" 4.0mm OFFSET

ALIGNED

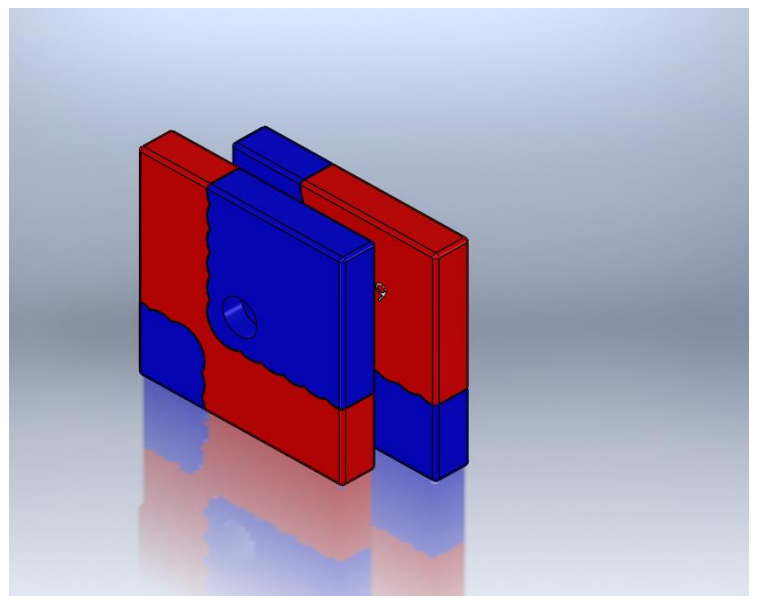
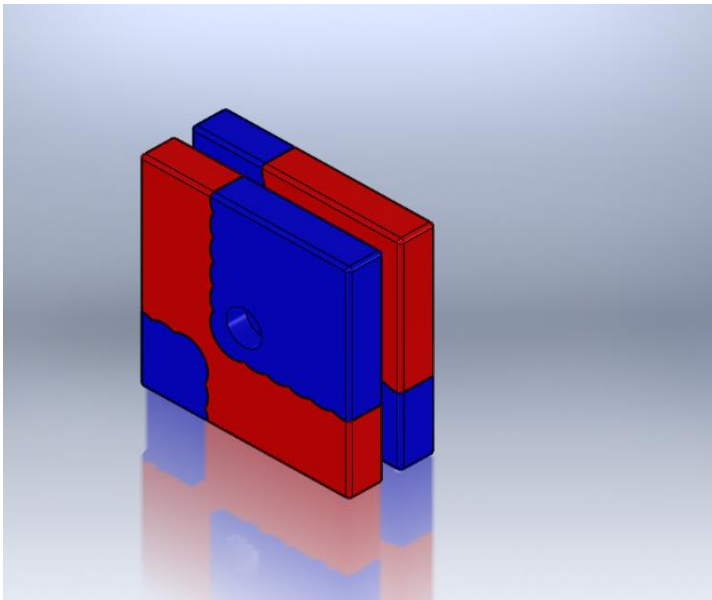

### HOLDING FORCE VS HORIZONTAL DISPLACEMENT AT 1.5MM MAGNET TO MAGNET GAP

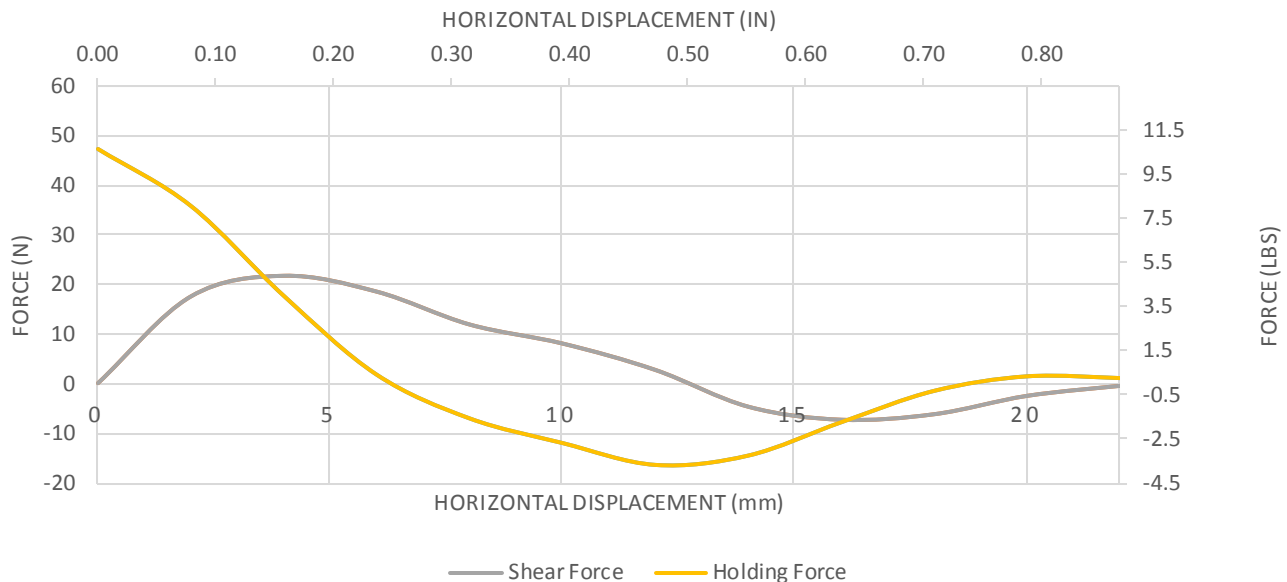

When a pair of 1002229/1002230 Polymagnets are laterally offset their attractive force decreases while their centering force increases. The magnets will have minor detents and a relatively low holding force when they are offset. This feature can be incorporated into a system to give feedback to the user during an assembly process.

#### Notes on Performance Data

The performance information provided in this data sheet is derived from test or simulation results of directly comparable magnets of the same size and grade under consistent conditions. The magnets are tested under controlled environmental conditions. Unconstrained application testing may give lower forces due to the magnet tilting or shifting away from target during engagement and disengagement.

#### Patent Information

Pat. [www.cmrpatents.com](http://www.cmrpatents.com)

